



Adaptor sleeves for MT with tang DIN 6383
Douilles de réduction pour CM à tenon DIN 6383



Verwendung:
Zur Aufnahme von Werkzeugen mit Morsekegelschaft und Austreibblappen nach DIN 228-1 Form B.

Application:
For mounting tools with Morse taper shank and tang according to DIN 228-1 form B.

Application:
Pour le serrage d'outils avec queue cône Morse et tenon suivant DIN 228-1 forme B.

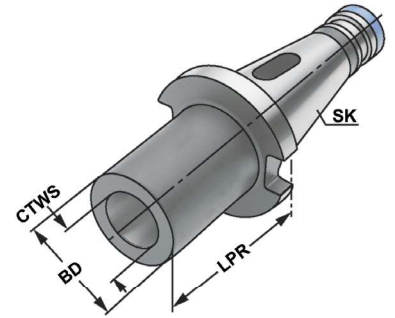

4

DIN 2080	Form AD	≤ 5µm	G6,3 15.000 min ⁻¹	DIN 6383	AT5
----------	---------	-------	-------------------------------	----------	-----

Bestell-Nr. Order no. Référence	SK	CTWS	TDCON	LPR	BD
301.07.01	SK 30	1	AT5	50	25
301.07.02	SK 30	2	AT5	50	32
301.07.03	SK 30	3	AT5	75	40
401.07.01	SK 40	1	AT5	50	25
401.07.02	SK 40	2	AT5	50	32
401.07.03	SK 40	3	AT5	65	40
401.07.04	SK 40	4	AT5	95	48
501.07.01	SK 50	1	AT5	45	25
501.07.02	SK 50	2	AT5	60	32
501.07.03	SK 50	3	AT5	65	40
501.07.04	SK 50	4	AT5	70	48
501.07.05	SK 50	5	AT5	105	63

